

Job Name: _____

Type: _____

Part #: _____

Notes: _____

Discontinued 07/2023

LLLEDR-2

LED ADJ USTABLE OPTICS THERMOPLASTIC EMERGENCY UNIT

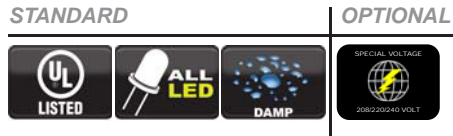

ILLUMINATION

- Long life, efficient, ultra bright white LED lamp heads.
- 1.0 watt (8 LEDs x 0.125W) per head.
- High performance, chrome-plated metallized reflector and plastic lens for optimal light distribution.
- Two adjustable LED lamp heads provide optimal center-to-center spacing.

ELECTRICAL

- Dual 120/277 voltage standard.
- Charge rate/power "ON" LED indicator light and push-to-test switch for mandated code compliance testing.
- 3.6V long life, maintenance-free, rechargeable NiCd battery.
- Internal solid-state transfer switch automatically connects the internal battery to LED lamps for minimum *omminute emergencymination*.
- Fully automatic solid-state, two rate charger initiates battery charging to recharge a discharged battery in 24 hours.

MOUNTING

- *Universal knockout pattern on back plate for surface mount. Snaps into place making internal electrical connections.*
- *Suitable for wall or ceiling mount.*
- *Knockout for conduit applications.*

HOUSING

- Injection-molded, engineering grade, 5VA flame retardant, high-impact resistant, thermoplastic in white or black finish.

ORDERING INFORMATION

MODEL	HOUSING COLOR		OPTIONS	
LLLEDR-2	(blank)	White	SPV	208/220/240 Volt, 50/60Hz
	B	Black		



OPTIONS

- SPV: UL listed for 208/220/240 Volt, 50/60 . Hz.

WARRANTY / LISTING

- Five year warranty on all electronics and housing. Battery prorated for five years.
- Meets UL924, NFPA 101 Life Safety Code, NEC, OSHA, Local and State Codes.
- UL Listed for damp locations (0°C – 50°C).

DIMENSIONS

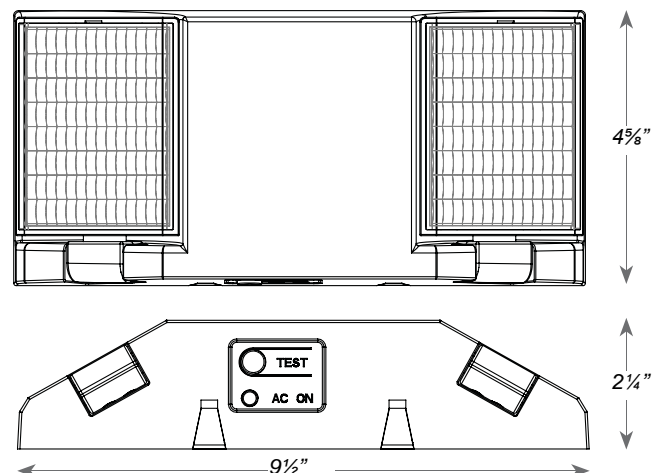

Job Name: _____

Type: _____

Part #: _____

Notes: _____

WIRE GUARDS

WIRE GUARD

- Durable 9-gauge steel construction.
- Mounting hardware provided for easy field installation.

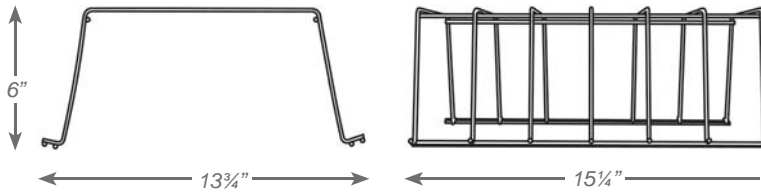

WG-1



VANDAL SHIELDS

HOUSING / MOUNTING

- High-impact resistant polycarbonate material.
- Mounting hardware provided for easy installation in the field.

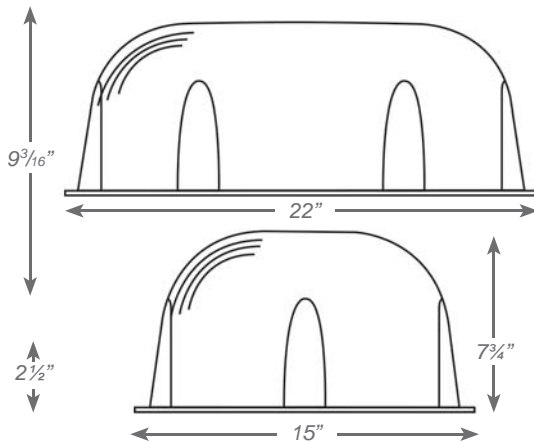

BG-1